

**INSTRUCTION SHEET**

for: **Part No. 5619 / 5619-24V**



**ADR - APPLICATION AND MOUNTING INSTRUCTIONS**

**LED SAFETY DAYLIGHTS™ (DRL) KIT - HORIZONTAL MOUNT**  
**5619: 12V DC Only**                              **5619-24V: 24V DC Only**

**Lens Marking and ADR 13/00 Installation Requirements**

This lamp module, identified by lens marking 0880, with clear lens was manufactured to comply with ADR 76/00 Daytime Running Lamp.

- Lamp module mounting surface must be vertical to the ground and facing forward.
- Lamp module reference axis must be parallel to the vehicle longitudinal axis.
- Lamp module centre line must be horizontal.
- Lamp module must be visible from 20° inboard and outboard, as well as from 10° above and below the horizontal axis.
- Two lamp modules are required.
- Lamps modules must not be mounted less than 250 mm and more than 1500 mm above the ground.
- Lamp modules must be mounted within 400 mm of the widest point of the vehicle and no closer than 600 mm together.

Notes: Please refer to ADR 13/00 for more details.

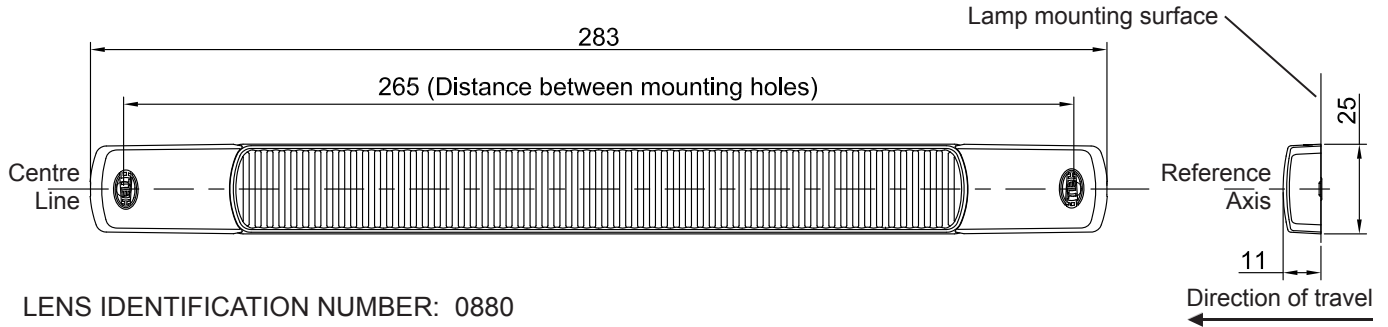

LENS IDENTIFICATION NUMBER: 0880

**Product Contents**

Description	5619	5619-24V
LED Safety DayLight™ with 2.5 m cable	x2	x2
Screw Cap	x4	x4
Mounting Screw	x4	x4
5 Pin Change-over Relay	x1 (P/N 3080)	x1 (P/N 3081)
Application and Mounting Instructions	x1	x1

CATALOGUE NUMBER	ENGINEERING NUMBER	CRN NUMBER	COMPLIANCE NUMBER	ADR 51/00 GLOBE	ADR APPLICABLE
1009 1009-24V	2PT 980 880-00 2PT 980 880-10	44200 44202	NDR12011802 NDR12011801	N/A LED	ADR 76/00
AMENDMENTS			ADR COMPLIANCE VERIFIED  	ISSUE DATE:	
04/2012	01/2014	02/2012			
			958 780-26		

**Hella-New Zealand Limited, Auckland.**

## INSTRUCTION SHEET

for: **Part No. 5619 / 5619-24V**



### Mounting Instructions

- **Lamp must be mounted horizontally on a flat surface with no curvature.**
- Drill two 3 mm Ø mounting holes at 265 mm centres through the mounting surface to allow fitment of the DRL. See previous page for correct positioning.
- Using the mounting screws tighten the DRL to the mounting surface (Maximum torque 1.5Nm).
- Fit screw caps.

Note: Do not overtighten the mounting screws in the plastic lens.

If it is necessary to remove the screw caps, lever them out with a small flat head screw driver.

### Wiring Instructions

- It is a legal requirement for daytime running lamps to illuminate only when the ignition is switched ON and the vehicle lighting is switched OFF.
- To meet this requirement it is recommended that a 5 pin change-over relay is utilised as per the wiring diagram below.

Wire Colour	Connect to	Power Consumption
Black	Terminal 31: Earth (-)	-
Red	Terminal 87a: DRL signal (+)	3 watts per lamp

Note 1: Lamps and relay must be protected by a fuse rated at 3 amperes maximum.

Note 2: Lamp is polarity conscious. The reversal of the polarity will not damage this product but will inhibit its function.

Note 3: Daytime running lamps are not a substitute for dipped beam headlights at dusk/dawn or during darkness.

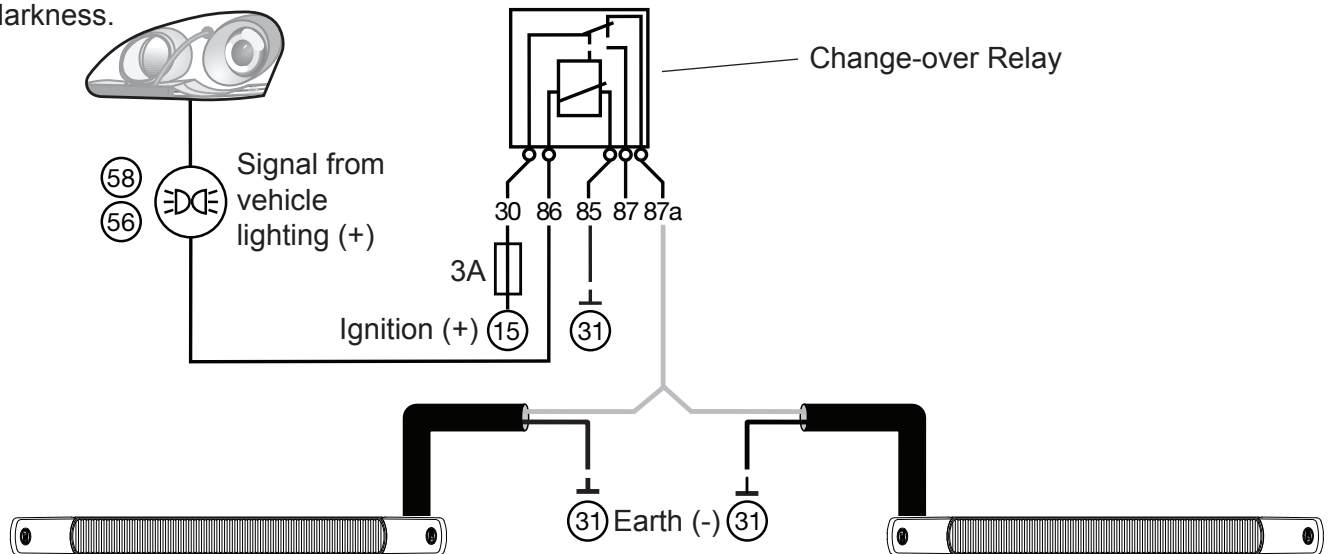

### **FIT AND FORGET - BY DESIGN**

Congratulations, the product you have selected comes from **HELLA** - a world leader in LED lighting design.

Following the launch of the first LED automotive signal lamps in 1990, **HELLA** Design and Innovation continues to set new standards. **HELLA** innovative solutions have been incorporated into millions of lamps, engineered and tested to the most stringent standards, to suit the most demanding environmental conditions.

The cornerstone to the success of our products is our no compromise **Fit and Forget - by Design** philosophy which is incorporated into every step of the product life cycle.

In a world consuming finite resources at an ever faster rate, **Fit and Forget - by Design** is the right environmental choice that also makes perfect economic sense to customers that consider the total life cycle Cost of Ownership.

For general comments about Hella's products please contact us on E-mail at [techfeedback@hella.co.nz](mailto:techfeedback@hella.co.nz)

