



INSTRUCTION SHEET
for: **2PF 980 855-xxx**

APPLICATION AND MOUNTING INSTRUCTIONS

**FRONT END-OUTLINE MARKER LAMP AND FRONT POSITION (SIDE) LAMP
Multivolt 12 / 24V DC**

Lens Marking and Installation Requirements

This lamp, identified by lens marking E24 5878, the backplate marking 02A, and the logo was manufactured to comply with ECE Regulation 7 for Front Position (Side) / Stop Lamps.

- Lamp mounting surface must be vertical to the ground and be square to the longitudinal axis of the vehicle.
- Lamp reference axis can be horizontal or vertical.

Front End-Outline Marker Lamp

- Lamp must be visible between - Horizontal angle: 0° inwards (parallel with vehicle axis) and 80° outwards
Vertical angle: 5° above and 20° below the horizontal

Front Position (Side) Lamp

- Lamp must be visible between - Horizontal angle: 45° inwards and 80° outwards
Vertical angle: 15° above and below the horizontal

Please refer to ECE Regulation 48 for more details.

General Dimensions (in millimetres)

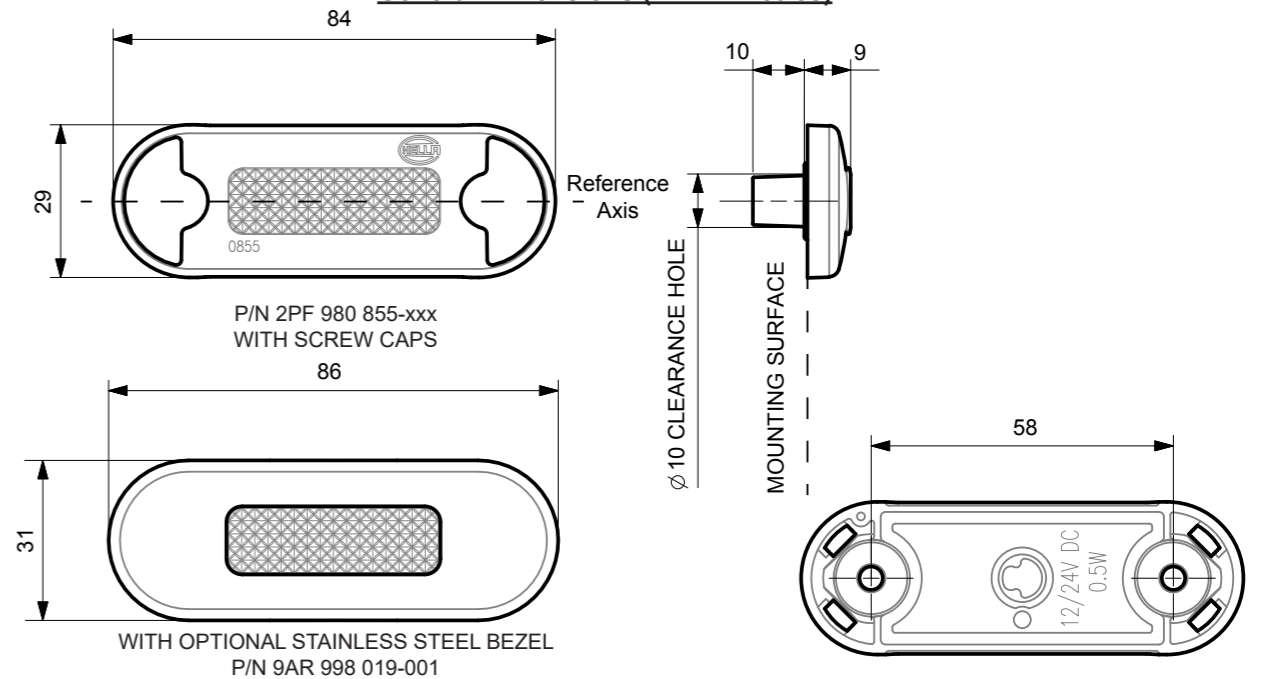

Lamp Mounting Instructions

- Lamp should be mounted on a flat surface with no curvature.
 - Drill a minimum hole size of $\text{Ø}10$ mm through the mounting surface for the centre cable exit. The lamp can then be used as a template to mark the location of the mounting holes.
 - Drill two mounting holes up to $\text{Ø}5.5$ mm at 58 mm centres through the mounting surface.
 - Fasten the lamp, with a maximum torque of 2.5 Nm, to the mounting surface using two $\text{Ø}5$ mm screws or bolts (not included). A maximum screw head height of 4 mm is recommended.
 - Once the lamp is mounted, clip the screw caps on securely until flush with the lens surface.
 - Or alternatively, clip the optional stainless steel bezel securely to the lens (see next page for illustration).
- Note: Do not use countersunk screws or overtighten the mounting screws in the plastic lens.
Lamp is fully sealed and has no serviceable components.

Compatibility to existing electrical systems

It is important for the installer to ascertain the compatibility of the low power consumption LED lamps with the electrical and/or electronic systems of the complete vehicle, including trailers. In most cases the reduced power consumption is beneficial by imposing less demands on the entire electrical system.

For certain functions some electrical systems rely on a set power consumption for monitoring whether, for example, a trailer is connected.

Operation of this lamp using alternating current or modulated direct voltage will cause premature light failure. HELLA recommends connecting ADR or ECE certified Multivolt LED signal and marker lamps to a continuous (unmodulated) 12V or 24V power supply to ensure safe light operation.

HELLA-New Zealand Limited, Auckland, New Zealand



HELLA-New Zealand Limited

Type: 0855

Hella Part 2PF 980 855-XXX, 2XA 980 855-XXX,
No.: 2PF 959 855-XXX, 2XA 959 855-XXX

13.10.2022

Mounting Instruction

Belongs to approval no.: E24 5878

(intended installation to ECE – R48)

Front Position- or Rear Position Lamp for Automobile

Light source(s): 2 LEDs

Test voltage: 13.5V or 28.0V

Nominal voltage: 12.0V or 24.0V

Nominal wattage: 0.5W

☒ = Centre of reference in accordance with the ECE-Regulation-No. 7.
Bezugspunkt nach der ECE-Regelung Nr. 7.

☑ = Centre of reference for the definition for illuminating surface in accordance with the Council Directive 76/756 EEC or ECE-Regulation No. 48 (see Annex A).
Bezugspunkt zur Bestimmung der Grenzen der leuchtenden Fläche nach 76/756 EWG bzw. ECE-Regelung Nr. 48.
Markierung s. auf der Abschluss-Scheibe. Maße s. Anlage A.

☒ = Axis of reference: Parallel to the car centre line and parallel to the road.
Bezugsachse: Parallel zur Fahrzeuglängsachse und parallel zur Fahrbahn.

☒ = Mounting of the horizontal installation is illustrated.
Der horizontale Einbau ist dargestellt.

☒ = The lamp may be used for horizontal or vertical mounting installation.
Die Leuchte darf verwendet werden für den horizontalen und vertikalen Einbau.

☒ = The lamp may be used with a stainless steel trim or with two screw caps.
Die Leuchte darf verwendet werden mit einem Edelstahlblech oder mit zwei Schraubenabdeckungen.



HELLA-New Zealand Limited

Type: 0855

Hella Part 2PF 980 855-XXX, 2XA 980 855-XXX,
No.: 2PF 959 855-XXX, 2XA 959 855-XXX

13.10.2022

Mounting Instruction

Belongs to approval no.: E24 5878

(intended installation to ECE – R48)

Front Position Lamp for Automobile

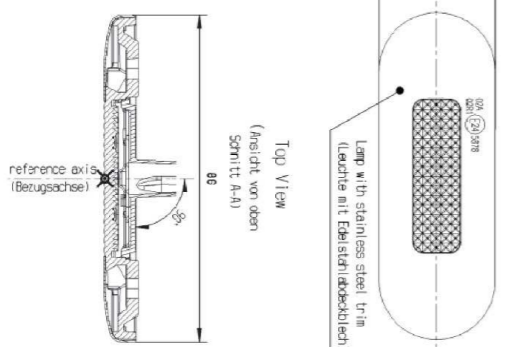
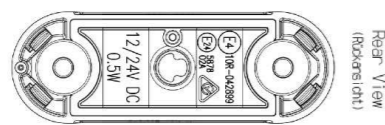
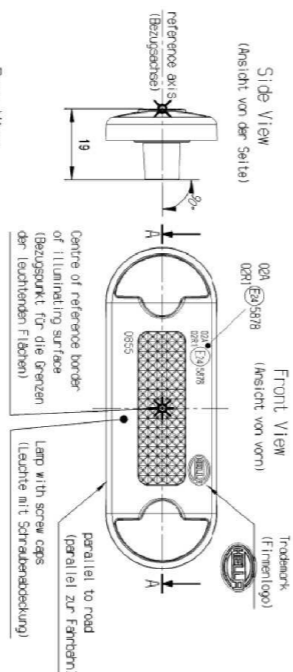

The lamp may be used for horizontal or vertical mounting installation.
Die Leuchte darf verwendet werden für den horizontalen und vertikalen Einbau.



INSTRUCTION SHEET
for: **2PF 980 855-xxx**

WITH OPTIONAL STAINLESS STEEL
BEZEL P/N 9AR 998 019-001

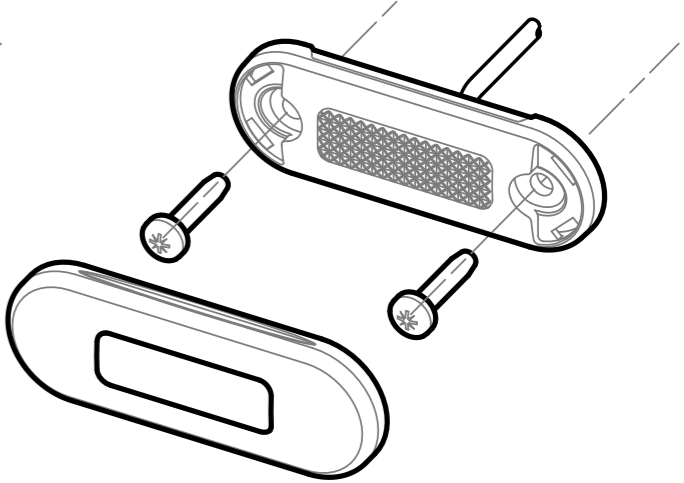

P/N 2PF 980 855-xxx
WITH SCREW CAPS

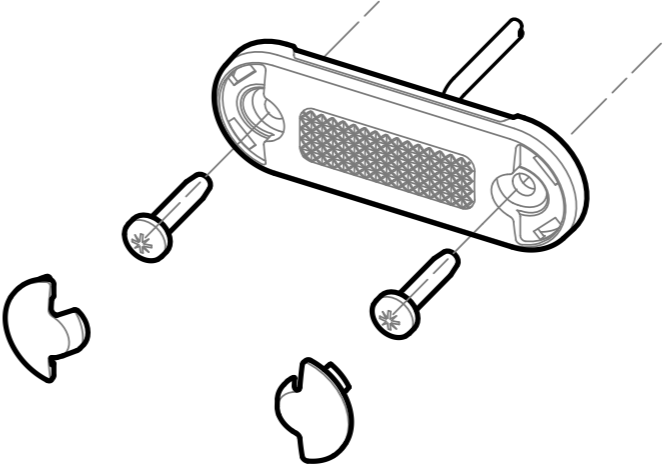

Wiring Colour Coding

The LED lamp is multi voltage capable for optimum brightness in 12 and 24 Volt systems. LED modules are polarity conscious. Reverse polarity will not damage this product but will inhibit its function. HELLA recommends wire connections be soldered, and heat shrink tubing applied to seal the joint.

Colour	Connect to	Power Consumption
Black	Earth (-)	-
Red	Positive (+)	0.5 W

NB: Lamp must be protected by a fuse rated at 2 amperes maximum.



NSAI

ECE TYPE-APPROVAL CERTIFICATE



Communication concerning:² ~~Approval granted~~
~~Approval extended~~
~~Approval refused~~
~~Approval withdrawn~~
~~Production definitively discontinued~~

of a type device pursuant to Regulation No. 7

Approval No: **E24*7R0227*5878*01**

Reason for extension:

See test report ITT4/0042 - 01, ITT4/0043 - 01 and accompanying manufacturer's information document for details

- Trade name or mark of the device:
- Manufacturer's name for the type of device:
Versions:

HELLA
0855

See test report ITT4/0042 - 01, ITT4/0043 - 01 and accompanying manufacturer's information document for details

- Manufacturer's name and address:
HELLA New Zealand Limited
81-83 Ben Lomond Crescent,
Pakuranga, Auckland, New Zealand
- If applicable, name and address of manufacturer's representative:
HELLA GmbH & Co. KGaA
Rixbecker Straße 75,
DE-59552 Lippstadt, Germany
As before and 03.11.2022
- Submitted for approval on:
As before and 03.11.2022
- Technical service responsible for conducting approval tests:
FAKT S.r.l.,
Via Lilloes, 53,
I-25086 Rezzato (BS), Italy
As before and 28.10.2022
- Date of test report issued by that service:
ITT4/0042 up to -01, ITT4/0043 up to -01
- Number of report issued by that service:

¹ Distinguishing number of the country which has granted/reissued/withdrawn approval (see approval provisions in the Regulation).
² Strike out which does not apply.

CT-11-13 Rev 9

NSAI, 1 Swift Square, Northwood, Sundry, Dublin 9, Ireland. Telephone: (+353+1) 807 3800, Facsimile: 01-807 3844



NSAI

Approval No: **E24*7R0227*5878*01**

9. Concise description:

9.1 By Category of lamps:

Front position lamp: A
Rear position lamp: R1

For mounting either outside or inside or both:

Outside

Colour of light emitted (red/selective yellow/white):

Front position lamp: White
Rear position lamp: Red

Number, category and kind of light source:

2, LEDs

Voltage and wattage:

12/24V - 0.5W

Light source module specific identification code:
Only for limited mounting height of equal to or less than 750 mm above the ground (yes/no):

No

Geometric conditions of installation and relating variations (if any):

Reference axis parallel to the median longitudinal plane of the vehicle and parallel to the bearing plane of the vehicle on the road (see drawings of the information document)

Application of an electronic light source control gear/variable intensity control
(a) being part of the lamp (yes/no):
(b) being not part of the lamp (yes/no):
Input voltage(s) supplied by an electronic light source control gear/variable intensity control:
Electronic light source control gear/variable intensity control manufacturer and identification number (when the light source control gear is part of the lamp but is not included into the lamp body):

No
No
N/A
N/A



NSAI

Approval No: **E24*7R0227*5878*01**

Variable luminous intensity (yes/no):

No

The front position lamp², rear position lamp², stop lamp², end-outline marker lamp² is only for use on a vehicle fitted with a tell-tale indication failure:

No

9.2 Function(s) produced by an interdependent lamp forming part of an interdependent lamp system:

Front position lamp	yes/no ²	No
R1 Rear position lamp	yes/no ²	No
R2 Rear position lamp	yes/no ²	No
S1 stop lamp	yes/no ²	No
S2 stop lamp	yes/no ²	No
S3 stop lamp	yes/no ²	No
S4 stop lamp	yes/no ²	No
End-outline marker lamp	yes/no ²	No

10. Position of the approval mark:

See drawings of the information document

11. Reason(s) for extension (if applicable):

See top of page 1 of certificate for details

12. Approval ~~granted/extended/refused/withdrawn~~:

Extended

13. Place:

Dublin

14. Date:

30th November, 2022

15. Signature:



NATIONAL STANDARDS AUTHORITY OF IRELAND
NSAI
Certification
TRANSPORT DEPARTMENT

16. The list of documents deposited with the Administrative Service which has granted approval, is annexed and may be obtained on request.