

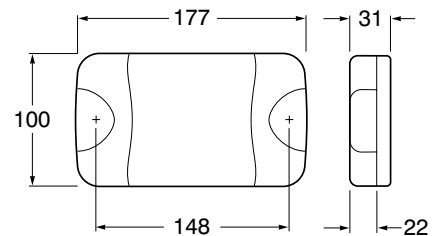

MOUNTING INSTRUCTIONS
for: **2XD 959 037-xxx / 959037xx**

DuraLED® Multi-Flash High Intensity Signal Lamp
Please retain for future reference

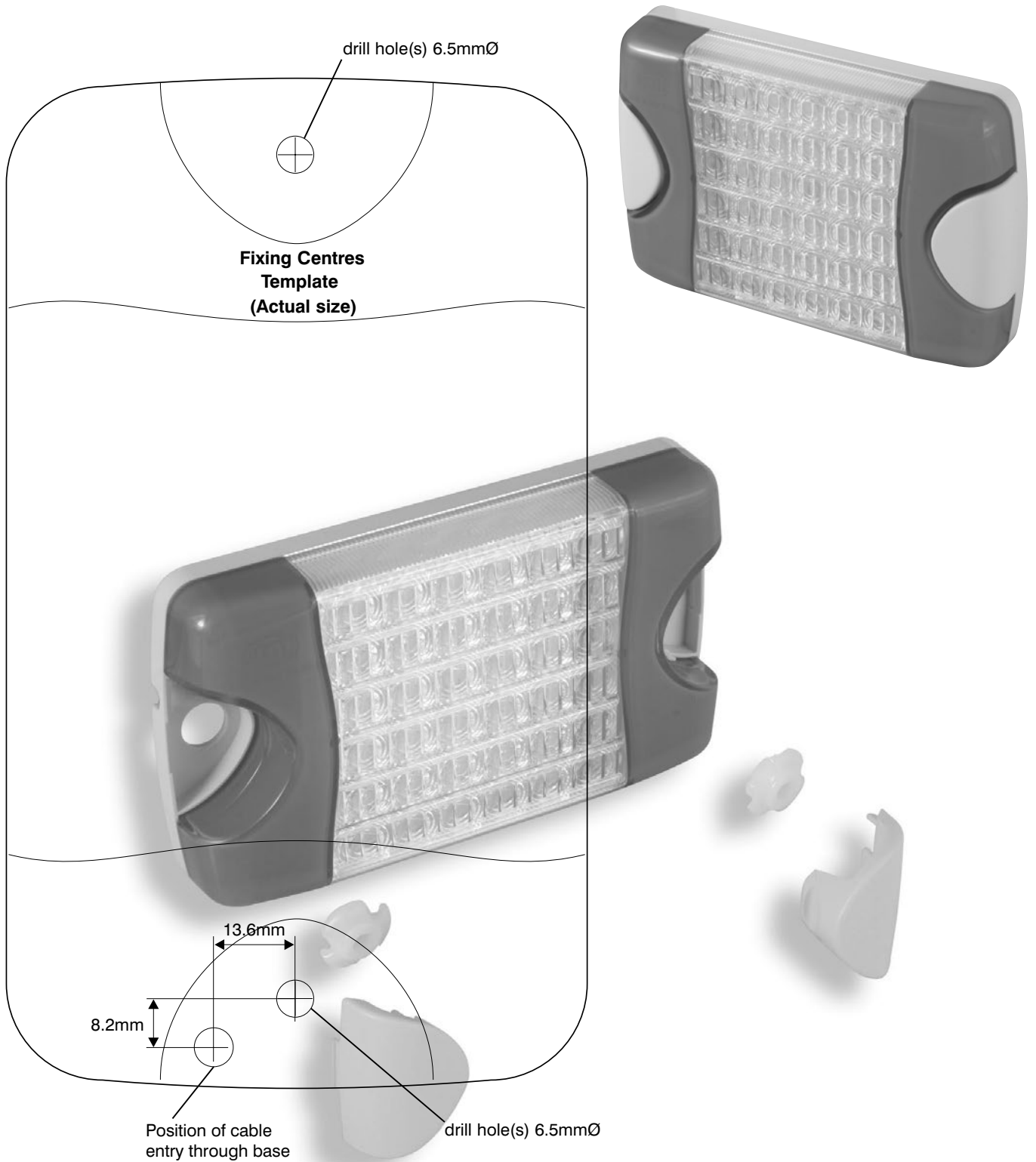



MOUNTING INSTRUCTIONS
for: **2XD 959 037-xxx / 959037xx**

DuraLED® Multi-Flash High Intensity Signal Lamp

Please retain for future reference

Technical data

Colour	Connect to	Power Consumption
White	Negative (-)	-
Red	On (+)	9 watts
Blue	Flash (+)	9 watts maximum
Brown	Sync	-

Features Include:

- Wide horizontal beam of +/- 15°
- Narrow vertical spread of +/- 5°
- **Multivolt** Capable (9-33volts)
- **SAE J595 Class 1** compliance on selected red and amber patterns.
Red flash patterns 1 to 6 and 9 / 10
Amber flash patterns 1 to 6

Lamp Mounting Instructions:

- Lamp should not be exposed to high temperatures eg from exhaust, radiators etc.
- Lamp mounting surface should be vertical to the ground.
- Lamp must be mounted horizontally for optimum wide angle light distribution.
- Lamp should be unobstructed by any part of the vehicle.

Screw Cap Removal

Carefully insert a small flat blade screwdriver between the cap and the lens and pull towards the lens, the cap will clip off.
To install the cap push in by hand until the top is flush with the lens.

Surface Mounting:

Drill two holes up to 6.5mm Ø at 148mm centres. 6mm Ø screws or bolts are recommended to mount the lamp using the mounting bushes provided. The lamp should be mounted on a flat surface.

- If passing the cable through a hole, ensure there are no sharp edges to cut or chafe the cable. Alternatively, cable can be routed through the end of the base.
- Connect cable as per chart above.
- Try to keep the cable length as long as possible, preferably join the cable inside a sealed cable junction box.
- Clip the screw caps on securely until flush with the lamp surface.

Note: When mounting lamp units side by side allow a gap of 5mm to ensure screw cap removal.

Wiring

Note: Lamp is polarity conscious.
The reversal of the polarity will not damage this product but will inhibit its function.

The On (red) cable is load dump protected by the transient voltage suppressor. The flash (blue) and sync (brown) cables may be permanently shorted to ground or to maximum operating voltage of 33 volts without damage to the circuit.

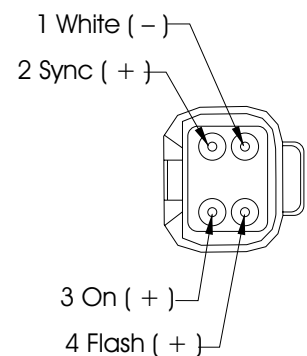

DT CONNECTOR VERSIONS
Hella P/N 959 850-00
Deutsch P/N DT04-4P

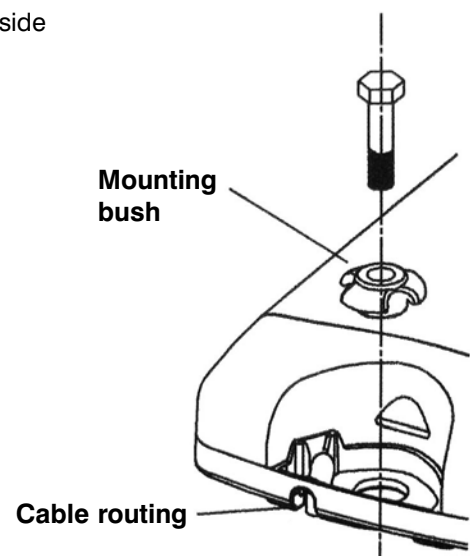

Note: Bolts not included



OPERATING INSTRUCTIONS
for: **2XD 959 037-xxx / 959037xx**

DuraLED® Multi-Flash High Intensity Signal Lamp
Please retain for future reference

Operating Modes

- **Steady State:** Lamp operates as a continuous on signal.
- **Flash State:** Lamp operates in the flash mode pre-selected by the user
- **Blitz State:** Lamp operates in bursts of quad flashes (intended for emergency situations)

Cable connections

Cable Colour	Steady	Flash	Blitz
White	Neg (-)	Neg (-)	Neg (-)
Red	Pos (+)	Pos (+)	Pos (+)
Blue	*	Pos (+)	Neg (-)
Brown	*	*	*

*Cable is isolated (not connected to positive (+) or negative (-))

Programming Mode (selecting a flash pattern)

The programming mode allows the user to select one of the 10 available flash patterns (see fig. 1)

Step by step instructions:

1. Connect On (red) cable to positive (+) and white cable to negative (-)
2. Connect flash (blue) cable to negative (-). *Blitz mode (program 4) will start flashing*
3. Connect sync cable (brown) to positive (+) *after approx 10 seconds the lamp will flash twice then stay on (steady state)*
4. The flash (blue) cable & sync (brown) cable should now be disconnected
***Note: ensure that the other cable connections are not disturbed (white and red). If power is interrupted, programming will need to be repeated from step 1 - if power was interrupted, blitz mode will activate each time flash (blue) is connected to negative (-)**
5. The previously selected flash pattern will now activate (*factory supplied default is flash mode 1*).
6. Connect then disconnect the flash (blue) cable to negative (-) to cycle / select the next flash pattern as shown in fig. 1 below
***Note connecting the flash (blue) cable to positive (+) will change the flash pattern off-set timing - please see the section "synchronise an array of lamps" before using this feature.**
7. Disconnect power from all cables for at least 10 seconds to save the currently selected flash pattern. (*When operating in flash state the pattern selected will now be used*)

Note: Lamp will automatically exit programming mode after approx. 65 seconds of inactivity on flash (blue) cable

Flash Pattern Timing (fig. 1)

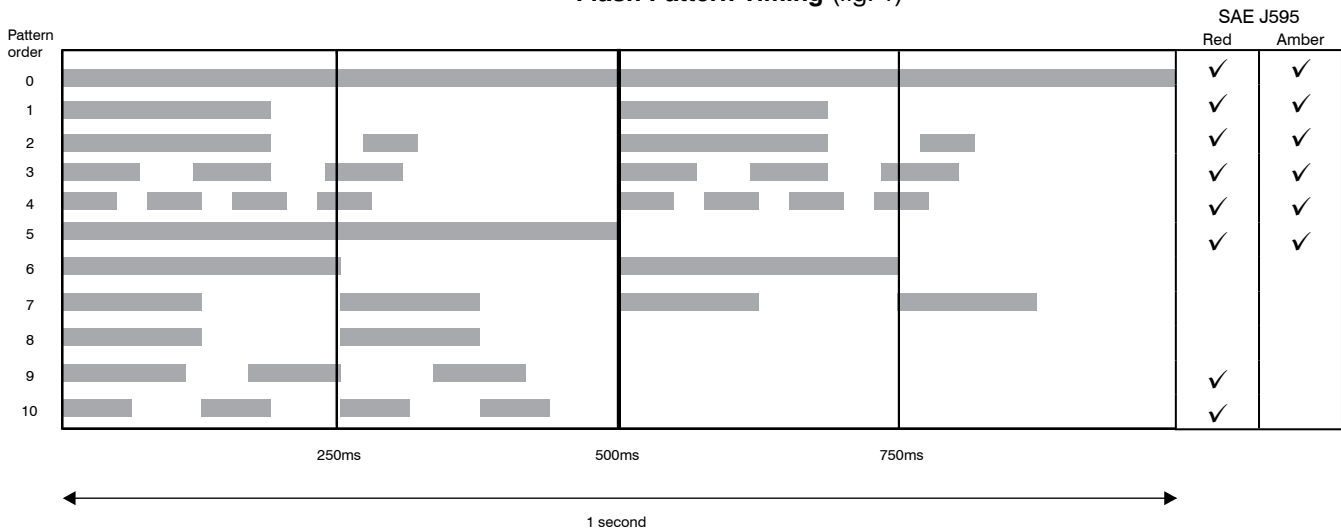



OPERATING INSTRUCTIONS
for: **2XD 959 037-xxx / 959037xx**

DuraLED® Multi-Flash High Intensity Signal Lamp
Please retain for future reference

Synchronise an array of lamps (2 to 4 lamps)

To control the timing of an "array" (multiple lamps connected together) so that the chosen flash patterns always start at the same time.

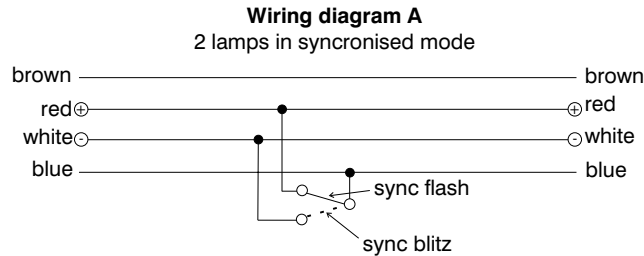

Step by Step instructions:

1. Individually program each lamp to the desired flash pattern as shown in the "Programming mode" instructions. *(it is recommended that the same flash pattern be selected for all lamps to be synchronised)*
2. Connect lamps as per wiring diagram A

Note:

It is recommended that the earth returns should be connected using low impedance wiring with no other significant ground currents in the ground wiring. It is not recommended to use the vehicle chassis for connecting the ground and ground loops must be avoided.

Off-set Flash Patterns

It is possible by adjusting the offset during the programming phase to ensure that all flash patterns can be synchronised together or opposed. The offset required to achieve this will be different depending on which flash pattern the user has chosen as the default. During **Step 6** of the programming instructions the flash pattern timing can be off-set by multiples of 250ms (90°) by connecting the flash (blue) cable to positive (+). (see fig 2. example)

By default all blue & green lamps will start with a 250ms delay to the red & amber lamps. This feature can also be used to create a "chase" function where by 4 lamps can be programmed to flash one after the other in sequence.

fig 2. 4 lamps using flash pattern 5, offset by 250ms (90°) each

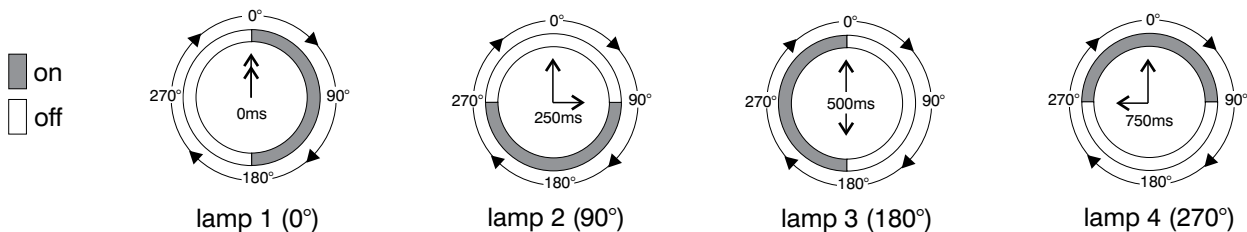

Important Notes for Installer

Introduction

Multivolt LED signal and marker lamps offer many advantages over conventional bulb lamps. Significantly reduced power consumption, ultra long life and high tolerance to shock and vibration make the LED lamps the ideal choice for the commercial operator, who values the economic cost of ownership versus the initial purchase price.

Electromagnetic Compatibility (EMC)

This Multivolt LED lamp is an electronic device. The electrical circuits contain components that suppress possible interference, both emission as well as susceptibility, to the technical requirements for the application of the Regulatory Compliance Mark (RCM). Additionally the electrical circuits conform to the limits prescribed in UNECE Vehicle Regulation No. 10.

To avoid false signals or interference, it is standard practice that sensitive instrumentation such as ABS and Tachometers etc. are provided with direct earths.

Operation of this lamp using alternating current or modulated direct voltage will cause premature light failure. HELLA recommends connecting ADR or ECE certified LED signal and marker lamps to a continuous (unmodulated) 12V or 24V power supply to ensure safe light operation.

Electric Welding

Electric Welding may damage the LED lamps. For LED lamps, Hella recommends the negative connection to be wired isolated from the vehicle chassis. If the lamp uses the chassis as the earth return it is recommended that this earth return is disconnected during electric welding.