



INSTRUCTION SHEET for: **2PT 980 68x-x01**

APPLICATION AND MOUNTING INSTRUCTIONS

83mm ROUND DAYTIME RUNNING LAMP

2PT 980 687-601 - 12V DC

2PT 980 686-601 - 24V DC

2PT 980 687-501 / 1006 - 12V DC

Features

- 12 LED design
- Low power consumption
- Reverse polarity protected
- Built-in spike protection
- Ultra long service life
- Fully sealed against dust and water
- Withstands most vibration and mechanical shock applications
- Manufactured from a high-performance lens material with enhanced impact and chemical tolerance
- Flush mount for low profile appearance

Lens Marking and Installation Requirements

This Daytime Running Lamp, identified by lens marking **E24**5921 and the **HELLA** logo, was manufactured to comply with:

ECE Regulation 87 for Daytime Running Lamps

- Lamp mounting surface must be vertical to the ground, and at right angles to the longitudinal axis of the vehicle.
- Lamp must be visible from 45° inboard and 80° outboard, as well as from 15° above and below the horizontal axis.
- Lamps must be mounted no less than 350 mm and no more than 1500 mm above the ground.
- Lamps to be mounted within 400 mm of the widest point of the vehicle and no closer than 600 mm together.
- Lamp is approved to be mounted only with lens engraving "TOP" located correctly.

Front View

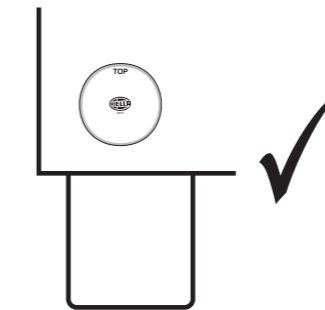
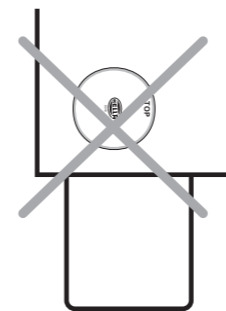

Top View

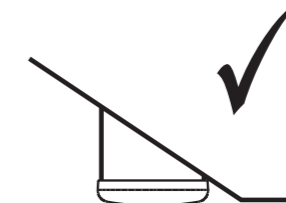
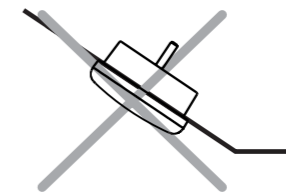

Side View

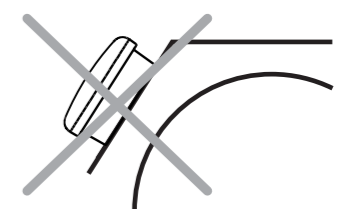

HELLA-New Zealand Limited, Auckland, New Zealand



HELLA-New Zealand Limited

Type: **2BE 980 686-xxx, 2BE 980 687-xxx**

Variant: **2BE 980 686-xxx, 2BE 980 687-xxx
2PT 980 686-xxx, 2PT 980 687-xxx,
980 686-xxx, 980 687-xxx**

Mounting Instruction

06.08.2019

Belongs to approval no.:

E24 2827 for ECE UN-R10 (12V)
E24 2828 for ECE UN-R10 (24V)
E24 5921 for ECE UN-R6, UN-R7, UN-R87 (12V/24V)

Daytime Running Lamp and/or Front Position Lamp and/or Direction Indicator, optionally grouped for Automobile: Categories L, M, N and T.

Optionally mounted behind a front screen with a transmission at least 85%.

Permission angle of the front screen:

$\alpha_{1,2}$ = up to / bis 115°
 $\beta_{1,2}$ = up to / bis 115°

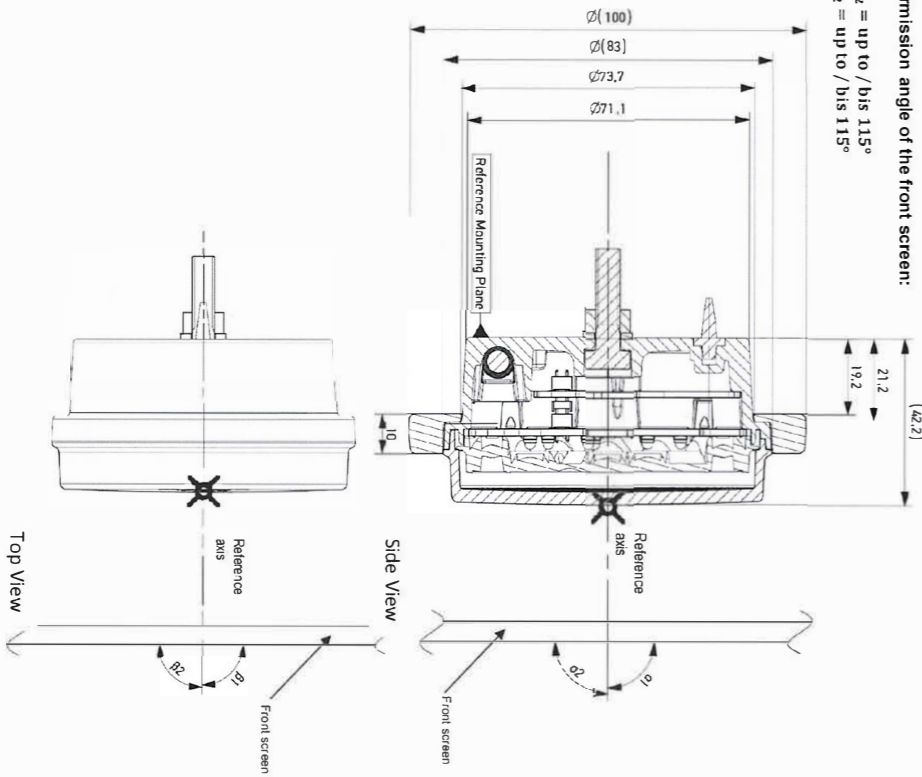

HELLA-New Zealand Limited

Type: **2BE 980 686-xxx, 2BE 980 687-xxx**

Variant: **2BE 980 686-xxx, 2BE 980 687-xxx
2PT 980 686-xxx, 2PT 980 687-xxx,
980 686-xxx, 980 687-xxx**

Mounting Instruction

06.08.2019

Belongs to approval no

E24 2827 for ECE UN-R10 (12V)
E24 2828 for ECE UN-R10 (24V)
E24 5921 for ECE UN-R6, UN-R7, UN-R87 (12V/24V)

Daytime Running Lamp and/or Front Position Lamp and/or Direction Indicator, optionally grouped for Automobile: Categories L, M, N and T.

Light source(s):	Design voltage:	Nominal voltage:	Nominal power:
Daytime Running Lamp	12 LEDs	13.5V	12.0W
Front Position Lamp	1 LED	13.5V	1.0W
Direction Indicator	12 LEDs	13.5V	12.0W
Light source(s):	Design voltage:	Nominal voltage:	Nominal power:
Daytime Running Lamp	12 LEDs	28.0V	24.0W
Front Position Lamp	1 LED	28.0V	24.0W
Direction Indicator	12 LEDs	28.0V	24.0W

◆ = Centre of reference in accordance with ECE-Regulation – No. 6, 7, 87.

◆ = Centre of reference for the definition for illuminating surface in accordance with the Council Directive 76/756 EEC or ECE-Regulation No. 48 (see Annex A)

Axis of reference: Parallel to the car centre line and parallel to the road.

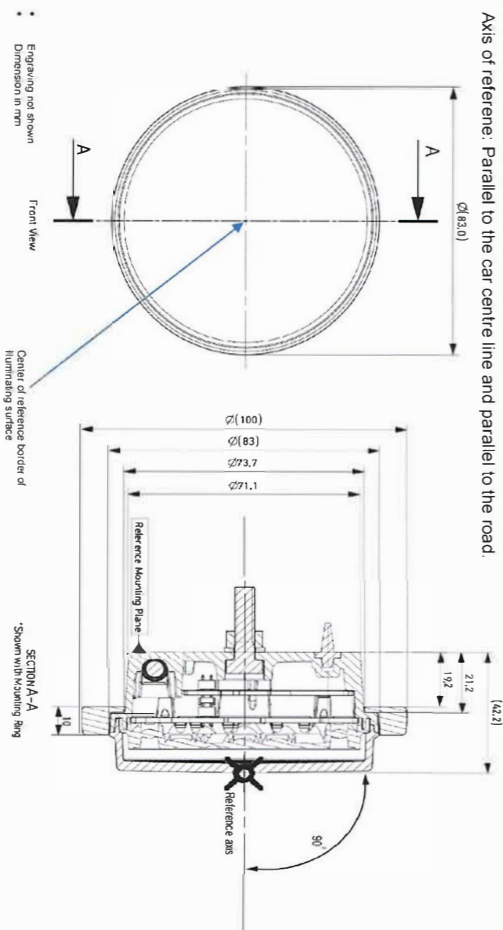

INSTRUCTION SHEET
for: **2PT 980 68x-x01**



Lamp Mounting

1/4" UNC Nut, bolt and washer have been supplied with this product.

Lamp should be mounted on a flat surface. Drill one mounting hole between 6.5mm and 8mm in diameter. A small 5mm location hole is also recommended to assist in mounting the lamp accurately and to stop the lamp from rotating during or after installation. This can be done using the supplied location pin.

If passing the cable through a hole, ensure there are no sharp edges to cut or chafe the cable.

Drill a cable exit hole 6mm diameter in the position as shown on diagram below.

Ensure the lens engraving "TOP" is located correctly.

Connect lamp wiring as per chart below.

Try to keep the cable as long as possible, preferably join the cable inside a sealed cable junction box.

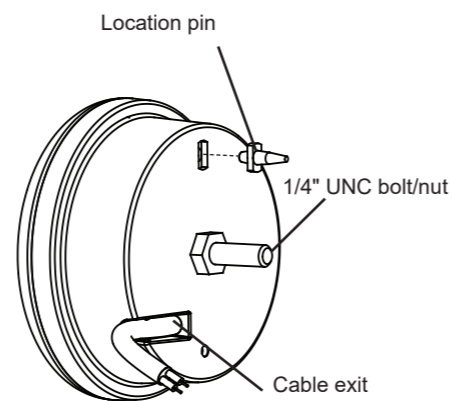

General Dimensions (mm)

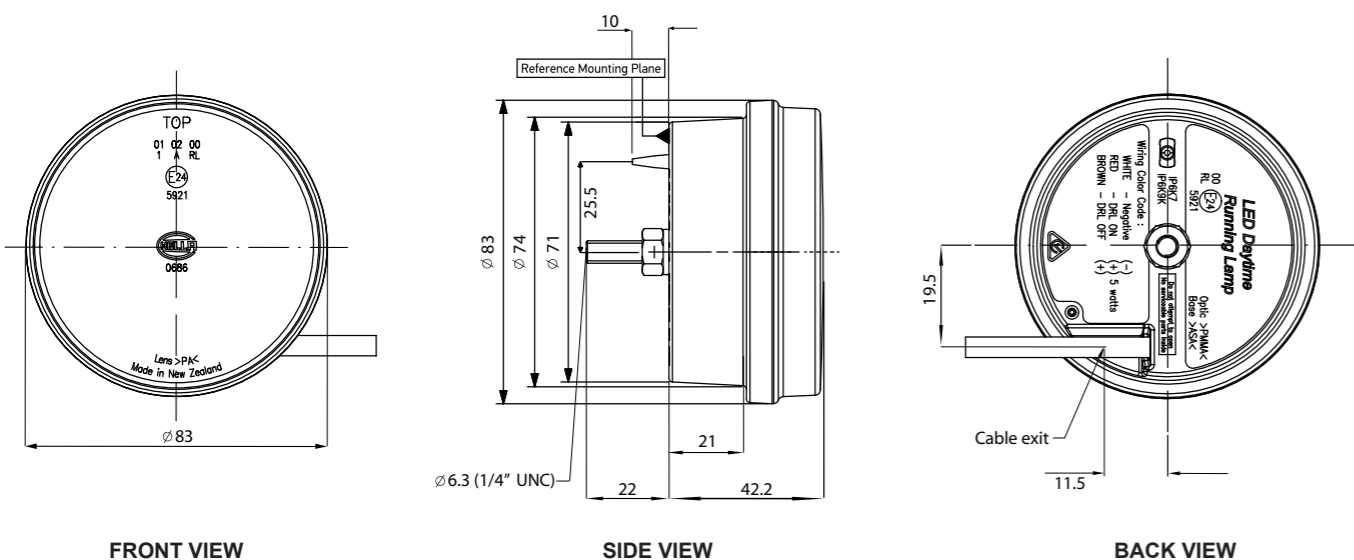

Wiring Colour Coding

LED modules are polarity conscious. Reverse polarity will not damage this product but will inhibit its function. HELLA recommends wire connections be soldered, and heat shrink tubing applied to seal the joint.

Colour	Connect to	Power Consumption	
		12V	24V
White	Negative (-)	-	-
Red	DRL ON (+)	5 watts	5 watts
Brown	DRL OFF (+)	-	-

NB: Lamp must be protected by a fuse rated at 3 amperes maximum.

Important Notes for Installer and Vehicle Owner



Introduction

LED signal and marker lamps offer many advantages over conventional bulb lamps. Significantly reduced power consumption, ultra long life and high tolerance to shock and vibration make the LED lamps the ideal choice for the commercial transport industry, where the cost of ownership versus the initial purchase price of the product is well understood.

Compatibility to existing electrical systems

It is important for the installer to ascertain the compatibility of the low power consumption LED lamps with the electrical and/or electronic systems of the complete vehicle, including trailers. In most cases the reduced power consumption is beneficial by imposing less demands on the entire electrical system. For certain functions some electrical systems rely on a set power consumption for monitoring whether, for example, an indicator globe has failed or a trailer is connected. Operation of this lamp using alternating current or modulated direct voltage will cause premature light failure. HELLA recommends connecting ADR or ECE certified LED signal and marker lamps to a continuous (unmodulated) 12V or 24V power supply to ensure safe light operation.

Electromagnetic Compatibility (EMC)

This LED lamp is an electronic device. The electrical circuits contain components that suppress possible interference, both emission as well as susceptibility, to the limits prescribed in UNECE Vehicle Regulation No. 10. To avoid false signals or interference, it is standard practice that sensitive instrumentation such as ABS and Tachometers etc. are provided with direct earths.

Protection against damage due to voltage spikes

This LED lamp is protected against damage from positive voltage spikes caused by events such as load dump conditions specified in ISO 7637-2.

The lamp is protected against reverse polarity connection and negative voltage spikes of up to 1000 volts.

Electric Welding

Electric Welding may damage the LED lamps. For LED lamps, HELLA recommends the negative connection to be wired isolated from the vehicle chassis. If the lamp uses the chassis as the earth return it is recommended that this earth return is disconnected during electric welding.

FIT AND FORGET - BY DESIGN

Congratulations, the product you have selected comes from **HELLA** - a world leader in LED lighting design.



Following the launch of the first LED automotive signal lamps in 1990, **HELLA** Design and Innovation continues to set new standards. **HELLA** innovative solutions have been incorporated into millions of lamps, engineered and tested to the most stringent standards, to suit the most demanding environmental conditions.

The cornerstone to the success of our products is our no compromise **Fit and Forget - by Design** philosophy which is incorporated into every step of the product life cycle.

In a world consuming finite resources at an ever faster rate, **Fit and Forget - by Design** is the right environmental choice that also makes perfect economic sense to customers that consider the total life cycle Cost of Ownership.

For general comments about HELLA's products please contact us on E-mail at techfeedback@hella.co.nz